

Optical Characteristics at TA = 25° C,IF=20mA.

Part Number	Lens Color	Wave length (nm)	Intensity (mcd)	Angle 2θ 1/2
FYL- 5033SRC1M	Water clear	660	90	110
FYL-5033LRC1M	Water clear	660	130	110
FYL-5033SURC1M	Water clear	630	330	110
FYL-5033NURC1M	Water clear	630	530	110
FYL-5033SUEC1M	Water clear	625	320	110
FYL-5033SUAC1M	Water clear	610	380	110
FYL-5033SUYC1M	Water clear	588	350	110
FYL-5033NUYC1M	Water clear	588	500	110
FYL-5033SUGC1M	Water clear	568	300	110
FYL-5033PGC1M	Water clear	520	1500	110
FYL-5033BGC1M	Water clear	505	1350	110
FYL-5033UBC1M	Water clear	470	600	110
FYL-5033VC1M	Water clear	410	90(mW)	110
FYL-5034UWC1M-UWW	Water clear	X:0.40 Y:0.39 CCT:3500k	800	110
FYL-5034UWC1M	Water clear	X:0.29 Y:0.30 CCT:9500k	800	110

LAMP PACKING.

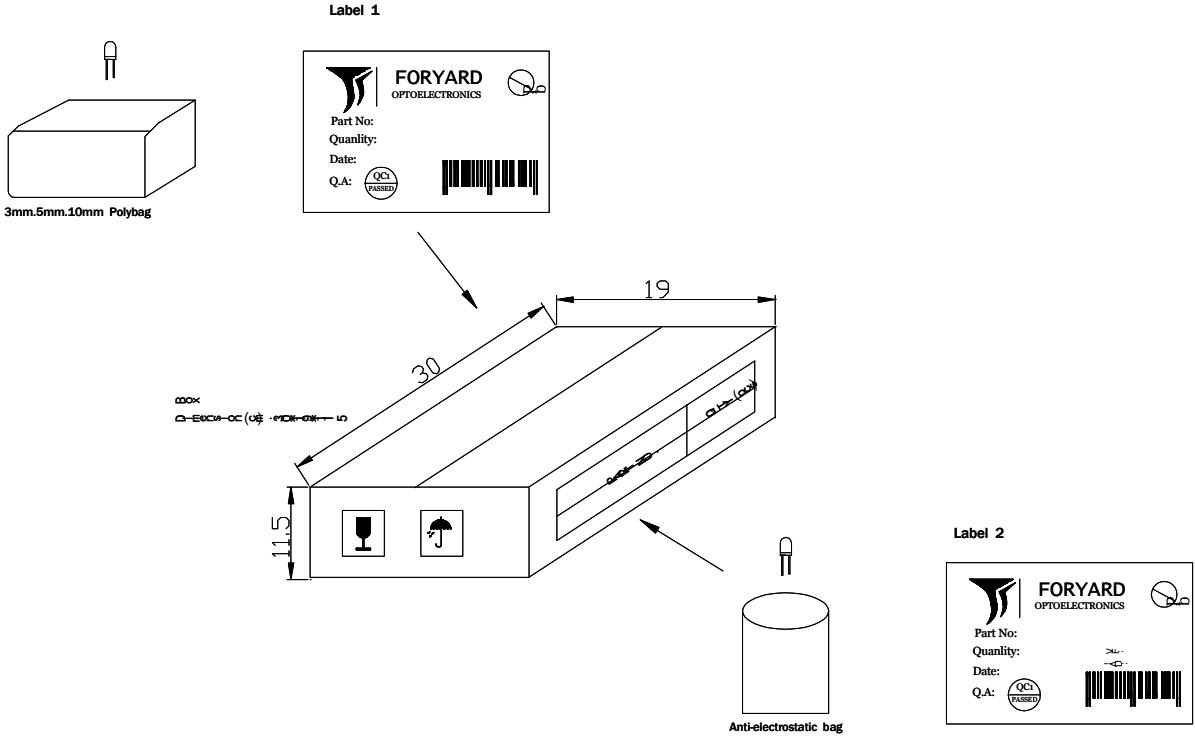

DEVICE	QTY/polybag(pcs)	Polybag/box A	Fig
5mm(T-1 3/4)	1000	8 bags	Label 1
3mm(T-1)	1000	10 bags	Label 1
10mm(T-1)	250	8 bags	Label 1
Blue/Green/White	500pcs	8 bags	Label 2

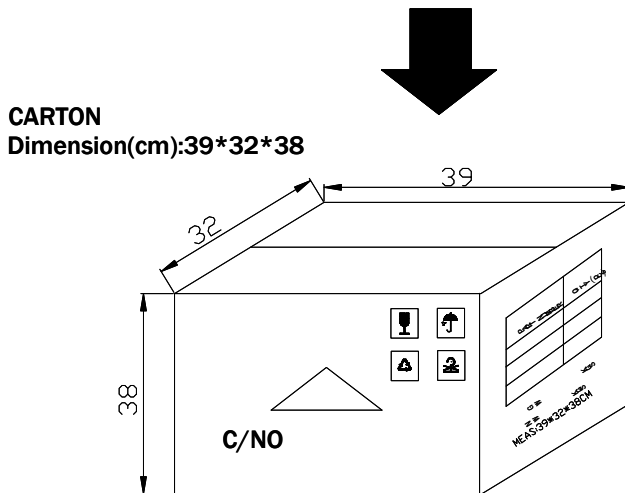

6 Boxes/Carton
 5mm:48,000pcs
 3mm:60,000pcs
 10mm:12,000pcs
 Blue/Pure Green/bluish Green
 /White:24,000pcs