

FYLP-1W-UBS

Features:

- Long operating life.
- Highest flux.
- Available in Blue.
- Lambertian radiation pattern.
- More energy efficient than incandescent and most halogen lamps.
- Low voltage DC operated.
- Cool beam, safe to the touch.
- Instant light (less than 100ns).
- Fully dimmable.
- No UV.
- Superior ESD protection
- Lower Rth
- ROHS compliant

Radiation Pattern

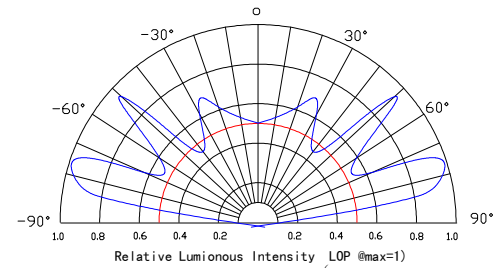

Package Dimensions

Applications

- Reading lights(car,bus,aircraft)
- LCD Backlights /light Guides
- Fiber optic alternative/Decorative/Entertainment
- Mini-accent/Up lighters/Down lighters/ Orientation
- Indoor/Outdoor commercial and Residential Architectural
- Cove/Under shelf /Task
- Bollards/Security/Garden
- Portable(flashlight,bicycle)
- Edge-lit signs (Exit, point of sale)
- Automotive Exit (stop –tail-Turn ,CHMSL,Mirror Side Repeat)
- Trafficsignaling /Beacons/rail Crossing and Wayside

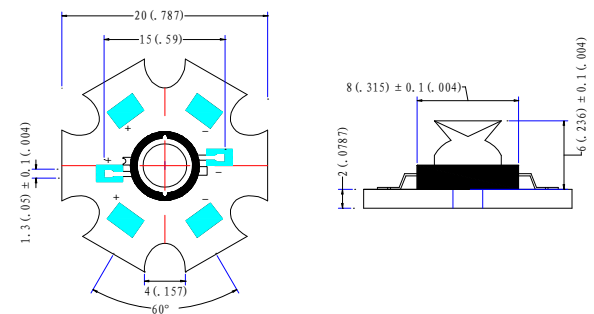

■ **Typical Optical/Electrical Characteristics@T_J=25°C**

Item	symbol	Condition	Min	Typ	Max	Unit
Forward Voltage	V _F	I _F =350mA	3.0	-	3.6	V
Reverse Current	I _R	V _R =5V			50	μA
50% Power Angle	2θ _{1/2}	I _F =350mA		175		deg
Luminous Intensity	Φ _v	I _F =350mA	5	7		LM
Recommend Forward Current	I _F			350		mA
Wave length	λ _d	I _F =350mA	460	-	470	nm
Thermal Resistance,Junction to Case	R _{jp}	I _F =350mA		10		°C/W

- Notes: 1. Tolerance of measurement of forward voltage ± 0.1v
 2. Tolerance of measurement of peak Wavelength ± 2.0nm
 3. Tolerance of measurement of luminous intensity ± 15%.

■ **Absolute Maximum Rating**

Item	symbol	Absolute Maximum Rating	Unit
Forward Current	I _F	350	mA
Peak Forward Current*	I _{FD}	500	mA
Reverse Voltage	V _R	5	V
Power Dissipation	P _D	1000	mW
Electrostatic discharge	ESD	4500	V
Operation Temperature	T _{OPR}	-30°C to +80°C	
Storage Temperature	T _{STG}	-40°C to +100°C	
Lead Soldering Temperature*	T _{SOL}	260°C for 3 Seconds Max	

- IFP Conditions :Pulse Width ≤ 10 msec duty ≤ 1/10
- All high Power emitter LED products mounted on aluminum metal-core printed circuit board, can be lighted directly ,but we do not recommend lighting the high power products for more than 5 seconds without a directly,but we do not recommend lighting the high powe products for more than 5 seconds without a appropriate heat dissipation equipment.
- Re-flow, wave peak and soak-stannum soldering etc. is not suitable for this products.
- Suggest to solder it by professional high power LED soldering machine.
- Can use invariable -temperature searing-iron with soldering condition: ≤ 260 degree less than 3 seconds.

■ Typical optical/Electrical Characteristics Curves (Tj=25°C Unless Otherwise Noted)

