

## FYLP-3W-UPGS

### Features:

- Very Long operating life
- Highest flux
- Available in Pure Green.
- Lambertian radiation pattern
- More energy efficient than incandescent and most halogen lamps
- Low voltage DC operated
- Cool beam,safe to the touch
- Instant light (less than 100ns)
- Fully dimmable
- No UV
- Lower Rth
- ROHS compliant

### Applications

- Reading lights(car, bus, aircraft)
- LCD Backlights /light Guides
- Fiber optic alternative/Decorative/Entertainment
- Mini-accent/Up lighters/Down lighters/ Orientation
- Indoor/Outdoor commercial and Residential Architectural
- Cove/Under shelf /Task
- Bollards/Security/Garden
- Portable (flashlight, bicycle)
- Edge-lit signs (Exit, point of sale)
- Automotive Exit (stop –tail-Turn ,CHMSL,Mirror Side Repeat)
- Traffic signaling /Beacons/rail Crossing and Wayside

### Radiation Pattern

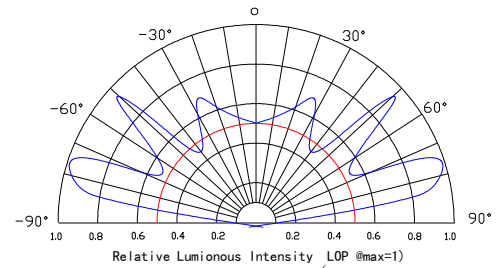

### Package Dimensions

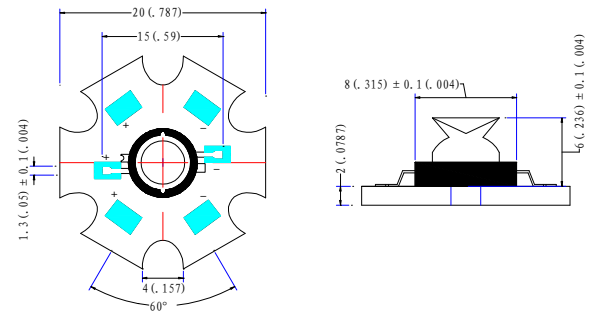

■ Typical Optical/Electrical Characteristics@T<sub>J</sub>=25°C

Item	symbol	Condition	Min	Typ	Max	Unit
Forward Voltage	V <sub>F</sub>	I <sub>F</sub> =800mA	3.4	3.6	4.0	V
Reverse Current	I <sub>R</sub>	V <sub>R</sub> =5V			50	uA
50% Power Angle	2θ <sub>1/2</sub>	I <sub>F</sub> =800mA	-	175	-	deg
Luminous Intensity	Φ <sub>v</sub>	I <sub>F</sub> =800mA	70	80		LM
Recommend Forward Current	I <sub>F</sub>			800		mA
Wave length	λ <sub>d</sub>	I <sub>F</sub> =350mA	515	520	525	nm
Thermal Resistance,Junction to Case	R <sub>jp</sub>	I <sub>F</sub> =350mA		10		°C/W

- Notes: 1. Tolerance of measurement of forward voltage ± 0.1v  
 2. Tolerance of measurement of peak Wavelength ± 2.0nm  
 3. Tolerance of measurement of luminous intensity ± 15%.

■ Absolute Maximum Rating

Item	symbol	Absolute Maximum Rating	Unit
Forward Current	I <sub>F</sub>	800	mA
Peak Forward Current*	I <sub>FD</sub>	1200	mA
Reverse Voltage	V <sub>R</sub>	5	V
Power Dissipation	P <sub>D</sub>	3000	mW
Electrostatic discharge	ESD	± 4500	V
Operation Temperature	T <sub>OPR</sub>	-30°C to +80°C	
Storage Temperature	T <sub>STG</sub>	-40°C to +100°C	
Lead Soldering Temperature*	T <sub>SOL</sub>	260°C for 3 Seconds Max	

- IFP Conditions :Pulse Width ≤ 10 msec duty ≤ 1/10
- All high Power emitter LED products mounted on aluminum metal-core printed circuit board, can be lighted directly ,but we do not recommend lighting the high power products for more than 5 seconds without a directly,but we do not recommend lighting the high powe products for more than 5 seconds without a appropriate heat dissipation equipment.
- Re-flow, wave peak and soak-stannum soldering etc. is not suitable for this products.
- Suggest to solder it by professional high power LED soldering machine.
- Can use invariable -temperature searing-iron with soldering condition: ≤ 260 degree less than 3 seconds.

■ Typical optical/Electrical Characteristics Curves (Tj=25°C Unless Otherwise Noted)

